

Brateck



LDT118-C012-W
LDT118-C012-B
LDT118-C024-W
LDT118-C024-B

ELITE

Mechanical Spring
Monitor Arms

Lead the Modernity.



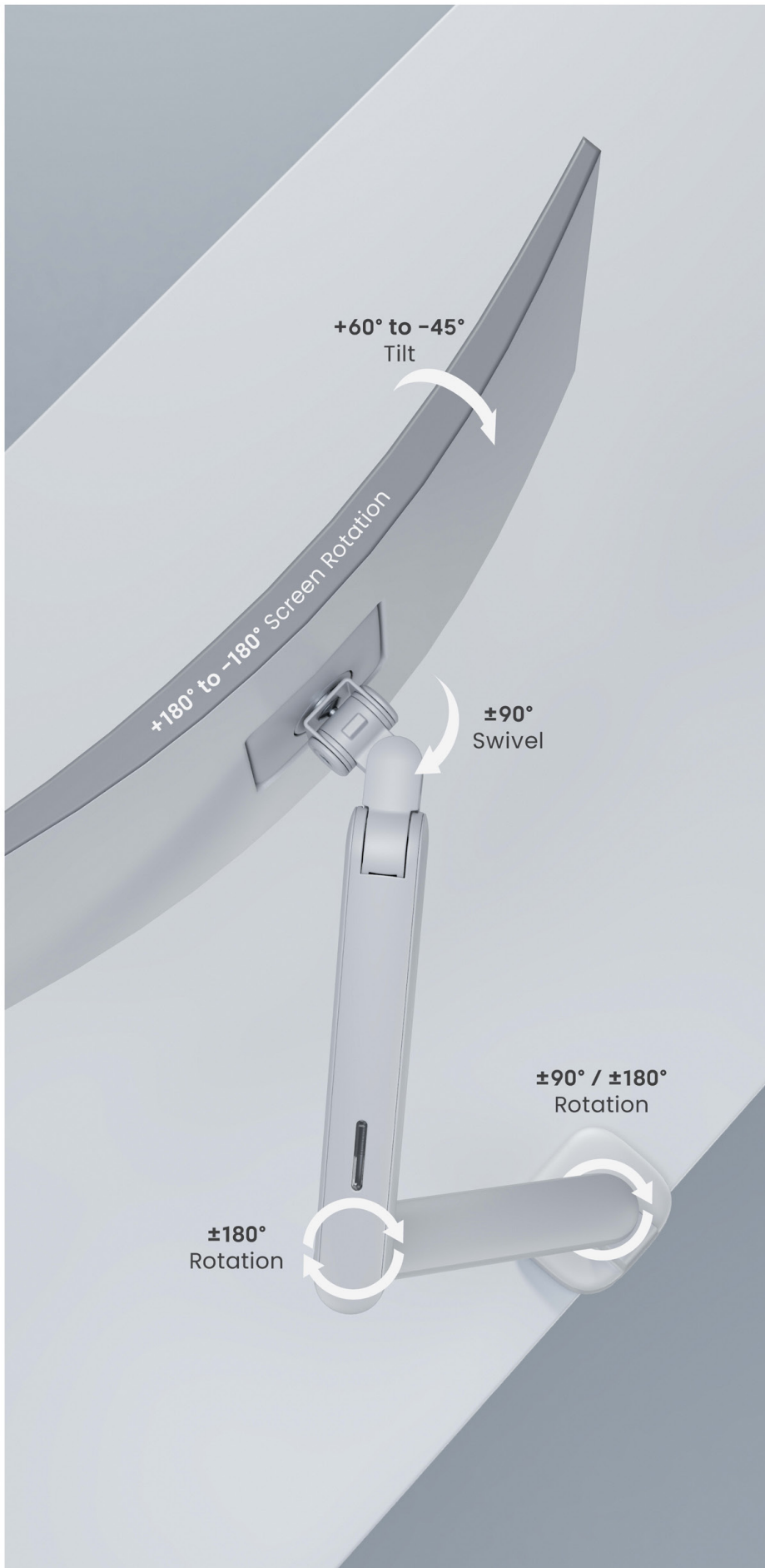

Built-in One-Way Bearing

- directional control
- more effortless & quiet tilting
- enhanced durability

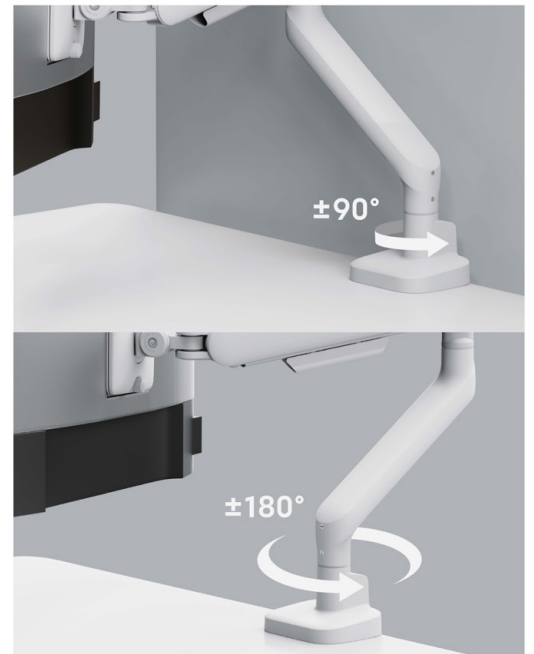

Rotation Stop

prevents the arm from hitting walls or partitions





Built-In Spring Tension Mechanism

- perfect balance
- optimized height adjustment



Quick-Release VESA Plate and Joints

simplify assembly for users and reduce package sizes for e-commerce



Easy Topside Installation

no more crawling under desks

LDT118-C012-W



LDT118-C012-B



Dimensions (mm)

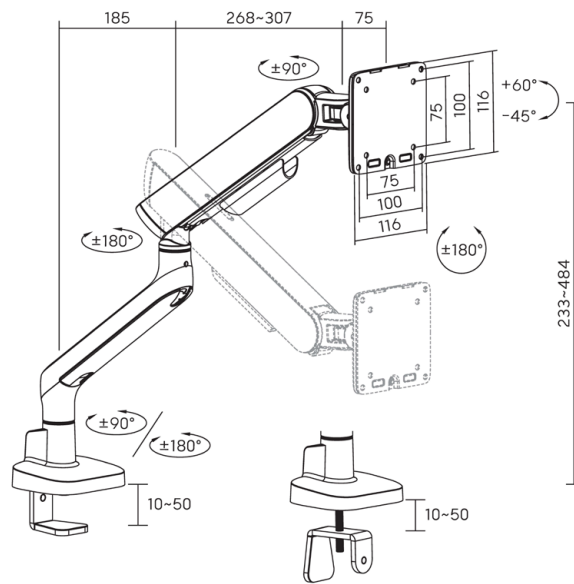

Item No.	LDT118-C012-W&LDT118-C012-B
Fit Screen Size	17" - 40"
Weight Capacity (per screen)	2~11kg (4.4lbs~24.2lbs)
VESA Compatible	75x75, 100x100
Tilt Range	+60°~-45°
Swivel Range	+90°~-90°
Screen Rotation	+180°~-180°
Material	Aluminum, Steel, Plastic

Color:

LDT118-C024-W



LDT118-C024-B



Dimensions (mm)

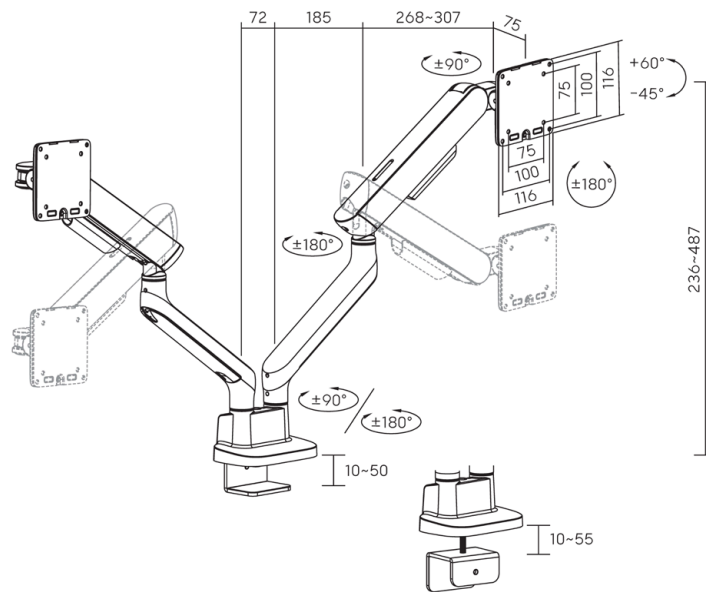

Item No.	LDT118-C024-W&LDT118-C024-B
Fit Screen Size	17" - 35"
Weight Capacity (per screen)	2~11kg (4.4lbs~24.2lbs)
VESA Compatible	75x75, 100x100
Tilt Range	+60°~-45°
Swivel Range	+90°~-90°
Screen Rotation	+180°~-180°
Material	Aluminum, Steel, Plastic

Color: